

ICS-2100 Ion Chromatography System



The ICS-2100 system is the first Reagent-Free™ ion chromatography system with electrolytic sample preparation (RFIC-ESP™ system) and eluent generation (RFIC-EG™ system) capabilities designed to perform all types of electrolytically generated isocratic and gradient IC separations using conductivity detection. Microbore 2 mm columns as well as standard bore 4 mm columns are fully supported. The ICS-2100 RFIC-ESP system now provides automation for many sample preparation techniques with multiple valving configurations and support for electrolytic sample preparation devices. The ICS-2100 system provides high performance with unequalled ease-of-use when coupled with an AutoSuppression® device, such as the SRS® 300 suppressor. Chromeleon® software provides full control and digital data collection from a PC using simple USB connectivity.

Versatility

- This integrated system performs all types of IC separations using conductivity detection.
- RFIC-EG system technology converts deionized water into high-purity eluents on-line.
- RFIC-ESP system accessories enable control of electrolytic sample preparation devices such as water purifiers and sample conditioners.
- Sample preparation capabilities extend the range of the instrument into areas, such as on-line filtration, matrix elimination, neutralization, and ultratrace analysis.
- The dual-piston pump design reduces pulsations, allowing high-sensitivity detection and excellent flow-rate accuracy and precision.
- Flexible flow rates support 2, 3, 4, and 5 mm column formats.
- The streamlined design with its small footprint occupies minimal bench space.
- An LCD touch-pad front panel provides clear identification of key operating parameters permitting at-instrument control and monitoring.



Passion. Power. Productivity.

Reagent-Free IC Systems

- Electrolytic eluent and regenerant production minimizes time, labor, operation costs, and eluent preparation errors.
- The eluent generator delivers sodium, potassium, and lithium hydroxide and carbonate/bicarbonate eluents for anion separations and methanesulfonic acid eluents for cation separations.
- Eluent generation provides the utmost in reliable, reproducible eluent concentrations from a supply of deionized water. Gradient elution becomes routine. EG-produced hydroxide eluents offer the lowest conductivity backgrounds possible.

Automated Sample Preparation

- Optional valving supports matrix elimination, sample concentration, and on-line filtration.
- Auxiliary power port supports electrolytic sample preparation devices.

Simple and Precise Control

- Control for the SRS and Atlas[®] electrolytic suppressors is built in. These AutoSuppression devices eliminate the need to manually prepare acid or base regenerants. Electrolytic suppression reduces background conductivity and provides high signal-to-noise ratios.
- Full control and digital data collection are available with the Windows[®]-based Chromeleon Chromatography Data System software using a USB high-speed communication protocol.
- Chromeleon eWorkflows preload all instrument parameters for fast and easy operation and data analysis.
- Chromeleon software includes an electronic logbook of nearly unlimited user-selectable operational parameters.

High Performance

- For improved reproducibility, the heated and thermostated high-performance conductivity detection cell permits measurements that are unaffected by temperature variation.
- Advanced single-range digital output provides an operating range to 15,000 μS full scale with autoranging to provide accurate detection of major and minor constituents in a single run. Single-range analog signal output is also standard.
- Column heater provides day-to-day consistency, ensuring reproducibility and stability. Preheating of the eluent prior to the column maintains the column temperature set by the user. A transparent cover allows viewing of the column without temperature disruption.
- Optional built-in vacuum degas provides in-line degassing of eluents, ensuring reproducibility and protection of eluents from contamination and decomposition. Control of the degas operation can be automated to sense when degassing is required.
- Inert, metal-free PEEK[™] components throughout the system ensure compatibility and metal contamination-free chromatography.

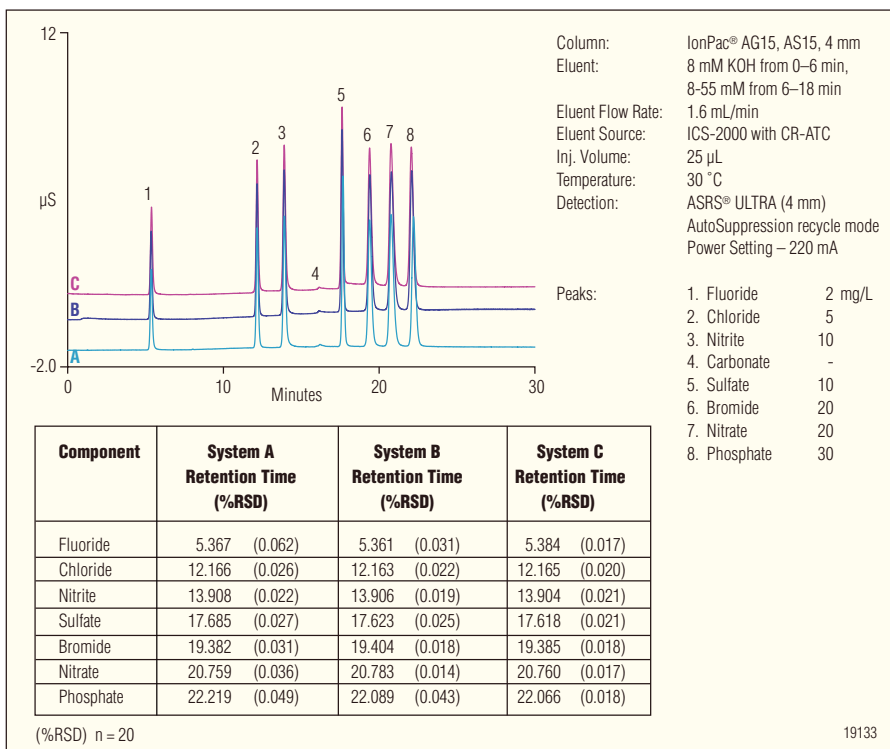

Reagent-Free IC systems produce consistent lab-to-lab eluent concentrations for highly reproducible retention times and peak areas. Results are the same day to day, system to system, and lab to lab.

Convenient

- Versatile eluent organizer tray. Accommodates 1-, 2-, or 4-L eluent bottles.
- Electrically actuated six-port Rheodyne PEEK injection valve.
- Ergonomically placed injection port for easy manual sampling.
- Eluent valve for positive shut-off of eluent flow prior to the pump for easy servicing.
- Easy-access door to chromatography components.
- Leak detection and management for fast response to system leaks.
- TTL controls for external pump, injection valve, range selection, and signal offset for stand-alone operation.

Key Features

- Automated eluent generation
- LCD front panel control
- Dual-piston pump
- Column heater
- Electrolytic suppression
- Digital conductivity detection
- Vacuum degas (option)
- Optional 6- or 10-port valve
- Optional RFIC-ESP water purifier
- USB connectivity, plug-n-play
- Electronic logbook and trending through virtual channels



All components are easily accessed through the front chromatography panel.

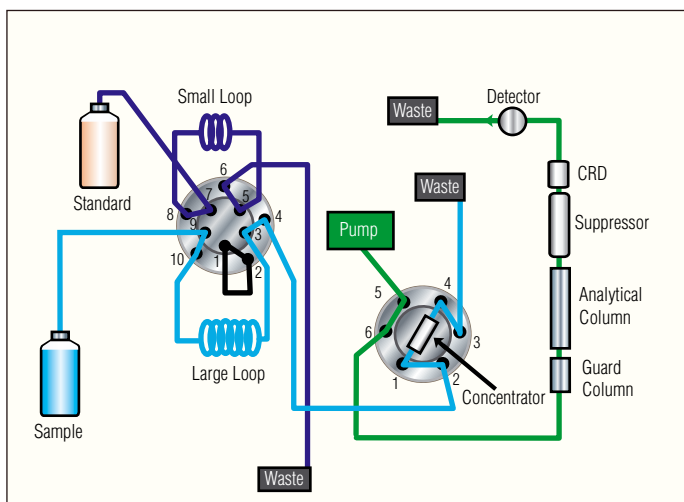

In RFIC-ESP systems, the optional water polisher also serves as a sample preparation pump, facilitating preconcentration or matrix elimination applications.

ICS-2100 IC SYSTEM SPECIFICATIONS

Analytical Pump and Fluidics

Type:

Serial dual-reciprocating pistons, microprocessor-controlled constant stroke, variable speed

Construction:

Chemically inert, metal-free PEEK pump heads and flow paths compatible with aqueous eluents of pH 0–14 and reversed-phase solvents

Pump Operating Pressure

0–35 MPa (0–5000 psi)

Flow Rate Range:

0.00–5.00 mL/min in 0.01 mL/min increments without changing pump heads

Flow Precision:

<0.1%, typically

Flow Accuracy:

<0.1%, typically

Pressure Ripple:

<1% at 13.8 MPa (2000 psi) and 1.0 mL/min

Eluent On-Off Valve:

Standard

Piston Seal Wash:

Dual-pump head, wash can be continuous when connected to rinse solution supply

Pressure Alarm Limits:

Upper limit 0–35 MPa or 0–5000 psi in one unit (MPa or psi) increments; lower limit can be set up to one unit lower than upper limit

Vacuum Degas:

Optional, automatic control

Eluent Bottles:

Polypropylene, up to 4 L volume

Eluent Bottle Pressure:

Not required

Injection Valve:

6-port, 2-position Rheodyne valve, electrically activated

Columns Supported:

2, 3, 4, and 5 mm i.d., maximum length 250 mm analytical column with 50 mm guard column

Column Heater (Standard)

Operating Temperature Range:

30 to 60 °C (86 to 140 °F); minimum 5 °C above ambient; settable range is equal to working range

Temperature Stability:

±0.5 °C at sensor

Temperature Accuracy:

±0.5 °C at sensor, at 40 °C

Eluent Generation (Standard)

Eluent Types

KOH, LiOH, NaOH
K₂CO₃, K₂CO₃/KHCO₃
MSA

Gradient Profiles

Option; combination of unlimited number of linear, convex and concave positive and negative gradient profiles

Concentration Increments

0.01 mM

Concentration Range

0.1–100 mM (depending on eluent used)

Flow Rate

0.1–3.0 mL/min

Maximum Operating Pressure

21 MPa (3000 psi)

Maximum Solvent Concentration

Anions: 25% methanol
Cations: no solvents

Auxiliary Power Supply (Standard)

Current:

Constant, 0–200 mA at up to 35 V

Alarms:

Overvoltage and overcurrent alarms; linked to pump flow to protect devices from power on at zero flow

Auxiliary Valve (Optional)

Available Valves:

6- or 10- port, 2-position high-pressure rheodyne valves, fully inert PEEK construction, electrically activated

Eluent Regeneration (Optional)

Eluent Regeneration Support:

With optional kit

Eluents:

Carbonate and carbonate/bicarbonate up to 20 mM
MSA up to 34 mM

Flow Rates:

0.01–2.00 mL/min

Continuous Operation (4 L of Eluent):

Up to 28 days or 2000 samples

Always On, Always Ready Capable:

Standard feature

Remains Fully Calibrated for Extended Periods (≤28 days):

Standard feature. results are traceable to a single calibration

System Wellness:

Consumables usage monitoring for predictive maintenance

Maximum Operating Pressure:

21 MPa (3000 psi)

Operating Temperature Range:

4–40 °C

Suppressors and Control

Chemical Suppression:

2 mm and 4 mm anion and cation, membrane suppression bed types

Displacement Chemical Regeneration:

2 mm and 4 mm anion and cation, membrane suppression bed types

Electrolytic Suppression—Self-Regenerating:

2 mm and 4 mm anion and cation, membrane and MonoDisk™ suppression bed types available

Electrolytic Suppression—Self-Regenerating with External Water Mode:

2 mm and 4 mm anion and cation. Both membrane and MonoDisk suppression bed types available

Current Control Range:

SRS:
4 mm, 0–300 mA in 1 mA increments
2 mm, 0–100 mA in 1 mA increments
AES®: 0–150 mA in 1 mA increments
CMD: 0–500 mA in 1 mA increments
SRN: 0–500 mA in 1 mA increments

Salt Converter:

Available in 2 and 4 mm versions

AMMS-ICE:

Available in 2 and 4 mm versions

Carbonic Acid Removal for Anions:

ASRS® 300 with CRD 200 for hydroxide eluents
ASRS 300 with CRD 300 for carbonate eluents

ICS-2100 IC SYSTEM SPECIFICATIONS (CONT'D)

Non-Suppressed Chromatography:
Supported

Suppressor Wear Parts:
None; peristaltic pump and inline filters not required

Suppression Capacity:
Anion SRS 300 (4 mm): 200 µeq/min
Cation SRS 300 (4 mm): 110 µeq/min
Anion SRS 300 (2 mm): 50 µeq/min
Cation SRS 300 (2 mm): 37.5 µeq/min
Anion MMS™ 300 (4 mm): 150 µeq/min
Cation MMS 300 (4 mm): 150 µeq/min
Anion MMS 300 (2 mm): 37.5 µeq/min
Cation MMS 300 (2 mm): 37.5 µeq/min
Anion AES: 25 µeq/min
Cation AES: 25 µeq/min

Void Volumes:
SRS 300 (4 mm): <50 µL
SRS 300 (2 mm): <15 µL
MMS 300 (4 mm): <50 µL
MMS 300 (2 mm): <15 µL
AMMS-ICE 300 (4 mm): <50 µL
AMMS-ICE 300 (2 mm): <15 µL
Anion AES: <35 µL
Cation AES: <35 µL

Conductivity Detector Electronics and Flow Cell

Type:
Microprocessor-controlled digital signal processor

Cell Drive:
8 kHz square wave

Linearity:
1% up to 1 mS

Resolution:
0.00238 nS/cm

Full-Scale Output Ranges:
Digital signal range 0–15000 µS
Analog signal range 0–15000 µS

Electronic Noise:
±0.1 nS when background conductivity is 0–150 µS/cm
±2 nS when background conductivity is 151–3200 µS

Filter:
Rise times from 0 to 10 s, user selectable

Temperature Compensation:
Fixed at 1.7% per 1 °C at cell temperature

Temperature Range:
Ambient +7 °C, 30 to 55 °C

Temperature Stability:
<0.01 °C

Cell Electrodes:
Passivated 316 stainless steel.
Compatible with MSA

Cell Body:
Chemically inert polymeric material

Cell Volume:
<1 µL

Heat Exchanger:
Inert, tortuous path for low axial dispersion

Maximum Cell Operating Pressure:
10 MPa (1500 psi)

Autosampler

Automation Using Autosampler:
Dionex AS40, AS-DV, AS, AS-HV, or third-party autosamplers

Sequential/Simultaneous Injection
Depending on autosampler capabilities

Automated Dilution:
Available with AS Autosampler

Dilution Factor, AS Autosampler:
1:1 to 1:1000

Dilution Time, AS Autosampler:
15 seconds with sample overlap

Inline Sample Degassing:
Optional with CRD 300/200

Inline Filtration:
Yes, AS40 and AS-DV Autosamplers or inline filter

High Automation Flexibility:
Conditionals using Chromeleon and Autodilution License

System Software

- Chromeleon Chromatography Data System software, supports Windows XP or Vista
- Automated Procedure Wizards
 - System Wellness and Predictive Performance
 - Data trending plots (numerical device parameters)
 - Virtual Column Simulator (evaluation mode standard, isocratic and gradient optional)
 - Application templates
 - Multivendor automation support of 3rd party instruments (fully controls over 300 instruments)

from more than 30 manufacturers, including GC, HPLC, and MS) 3-D software for photodiode arrays, mass spectrometers, and electrochemical detectors (optional)

- Customizable system control panels
- System status Virtual Channels
- Power failure protection
- Sequential injection
- System trigger commands and conditionals
- Daily audit trail
- Sample audit trail
- Multiple network control and network failure protection (optional)
- System calibration storage (factory, present, and previous; completely user selectable)
- Customized reporting (unlimited report workbooks)
- Automated system qualification (detailed, comprehensive qualification reports)

Physical Specifications

Power Requirements:
100–240 V ac, 50-60 Hz autoranging

Operating Temperature:
4–40 °C (40–104 °F); cold-room-compatible (4 °C) as long as system power remains on

Operating Humidity Range:
5–95% relative, noncondensing

Control Modes:
Full control through front panel and Chromeleon software; alternative control through TTL or relay closures; two relay outputs, two TTL outputs, four programmable inputs

USB Communication Protocol:
One USB input; one built-in two-output USB hub

Leak Detection:
Built-in, optical sensor

Dimensions (h × w × d):
56.1 cm × 22.4 cm × 53.3 cm
(22.1 in × 8.8 in × 21 in)

Weight:
24.5 kg (54 lb)

ORDERING INFORMATION

In the U.S., call (800) 346-6390 or contact the Dionex office nearest you. Outside the U.S., order through your local Dionex office or distributor. Refer to the following part numbers.

ICS-2100 Ion Chromatography System with Software and PC

An ICS-2100/Chromeleon Windows Workstation bundled package includes: an ICS-2100 with isocratic dual-piston pump, eluent generator to run Full EG, injection valve, column heater, heated conductivity cell, LCD touch-pad front panel, USB cable, Chromeleon Computer (with Windows XP), and USB dongle. Comes with two Class 1 Timebases controlling one Dionex IC system. Consumables must be ordered separately.

ICS-2100 Ion Chromatography System with Full EG, Chromeleon, and Windows XP Workstation, without Degas.....	069656
ICS-2100 Ion Chromatography System with Full EG, Chromeleon, Windows XP Workstation and Degas.....	069657
ICS-2100 Ion Chromatography System with Full EG and Chromeleon, without Degas or PC.....	069658
ICS-2100 Ion Chromatography System with Full EG, Chromeleon, and Degas, without PC	069659
AutoDilution License	069725

PEEK is a trademark of Victrex PLC.

Windows is a registered trademark of Microsoft Corporation.

MonoDisk, Reagent-Free, RFIC-EG, and RFIC-ESP are trademarks and AES, ASRS, Atlas, AutoSuppression, Chromeleon, IonPac, and SRS are registered trademarks of Dionex Corporation.

Passion. Power. Productivity.



Dionex Corporation

1228 Titan Way
P.O. Box 3603
Sunnyvale, CA
94088-3603
(408) 737-0700

North America

U.S./Canada (847) 295-7500

South America

Brazil (55) 11 3731 5140

Europe

Austria (43) 1 616 51 25 Benelux (31) 20 683 9768; (32) 3 353 4294
Denmark (45) 36 36 90 90 France (33) 1 39 30 01 10 Germany (49) 6126 991 0
Ireland (353) 1 644 0064 Italy (39) 02 51 62 1267 Sweden (46) 8 473 3380
Switzerland (41) 62 205 9966 United Kingdom (44) 1276 691722

Asia Pacific

Australia (61) 2 9420 5233 China (852) 2428 3282 India (91) 22 2764 2735
Japan (81) 6 6885 1213 Korea (82) 2 2653 2580 Singapore (65) 6289 1190
Taiwan (886) 2 8751 6655

www.dionex.com



LPN 2198-01 PDF 04/09
©2009 Dionex Corporation